

# ASSEMBLY INSTRUCTION

## ASSEMBLY PROGRAM

### STEP 1

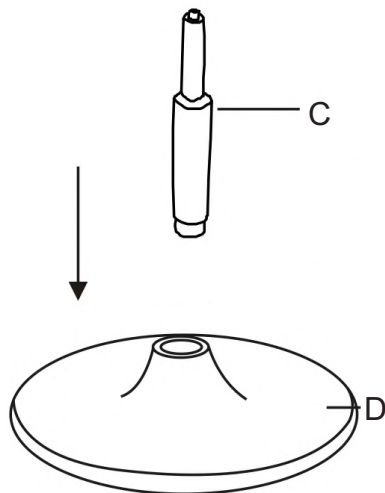

### STEP 2

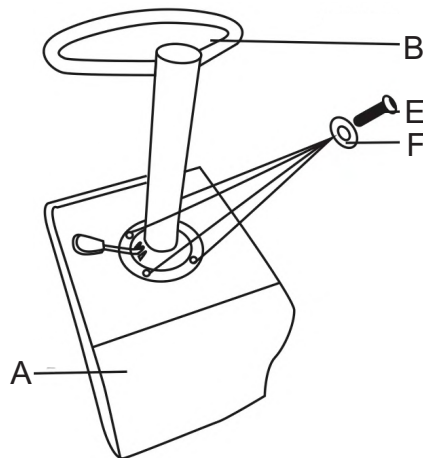



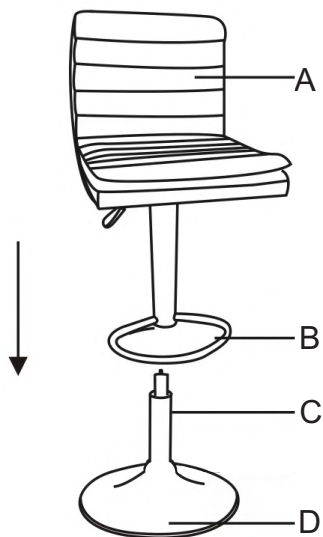



### STEP 3

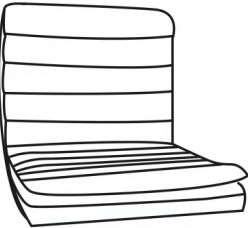

### FINISH



## PARTS x QTY

A=Seat Group x1	E=Screw(M6X18mm) x4
	
B=Tubular Column x1	F=Spacer(M6X18mm) x4
	
C=Gaslift x1	G=Spanner x1
	
D=Base x1	
